

To prevent accidents arising from the misuse of this controller, please ensure the operator using it receives this manual.



Caution

- This instrument should be used according to the specifications described in this manual. If it is not used according to the specifications, it may malfunction or breakdown.
- Be sure to follow the warnings, cautions and notices. If not, serious injury or accidents may occur.
- The specifications of the DCL-33A and the contents of this instruction manual are subject to change without notice.
- Care has been taken to assure that the contents of this instruction manual are correct, but if there are any doubts, mistakes or questions, please inform our sales department.
- Be sure to check that the power is turned off when cleaning this instrument.
- Use a soft and dry cloth when cleaning the instrument.
(If paint thinner is used, it might deform or tarnish the unit.)
- As the display section is vulnerable, do not strike or scratch it with a hard object.
- Any unauthorized transfer or copying of this document, in part or in whole, is prohibited.
- Shinko Technos is not liable for any damages or secondary damages incurred as a result of using this product, including any indirect damages.

1. Model name

1.1 Model name

DCL-3		3	A-	□/□, □□□□	Series name: DCL-300 (W22.5 x H75 x D100mm)	
Control action	3				PID	
Alarm	A				Alarm action is selectable by key operation *1	
Control output	R				Relay contact: 1a	
	S				Non-contact voltage (for SSR drive): 12 ⁺² ₀ Vdc	
	A				DC current: 4 to 20mAdc	
Input	M				Multi-range *2	
Option	W (5A)				Heater burnout alarm	CT rated current: 5A
	W (10A)					CT rated current: 10A
	W (20A)					CT rated current: 20A
	W (50A)					CT rated current: 50A
	C5				Serial communication	Based on EIA RS-485

*1: Alarm action (9 types and no alarm) and Energized/Deenergized are selectable by key operation.

*2: Thermocouple, RTD, DC current and DC voltage are selectable by key operation.

1.2 How to indicate model name label

Model name label is on the right side of the case and the bottom of the inner assembly.

In the case of Heater burnout alarm output, CT rated current value is written in the bracket ().

Model name -----	DCL-33A-R/M	Relay contact output/ Multi-range input
Option -----	W (20A)	Heater burnout alarm output
Option -----		
Instrument No. (Inner assembly only)--	No. XXXXXX	

2. Name and functions of the sections

(1) Event (EVT) output action indicator

A red LED lights when Event output [Alarm, Loop break alarm or Heater burnout alarm (Option)] is ON.

(2) Control output (OUT) action indicator

A green LED lights when the control output (OUT) is ON.

(3) Serial communication output indicator

A yellow LED blinks while serial communication TX (sending) is output.

(4) PID auto-tuning action indicator

A yellow LED blinks while PID auto-tuning is performing.

(5) PV display

Indicates actual temperature (PV) with a Red LED.

(6) SV display

Indicates setting value (SV) with a Green LED.

(7) ▲ key

Increases numeric value on the SV display or switches the selected item.

(8) ▼ key

Decreases numeric value on the SV display or switches the selected item.

(9) ⏪ key

Changes the setting mode or registers setting value and the selected value.
(Registers the setting value and selected value by pressing the ⏪ key.)

(10) ⏩ key

Selects the setting item with the ⏩ key.

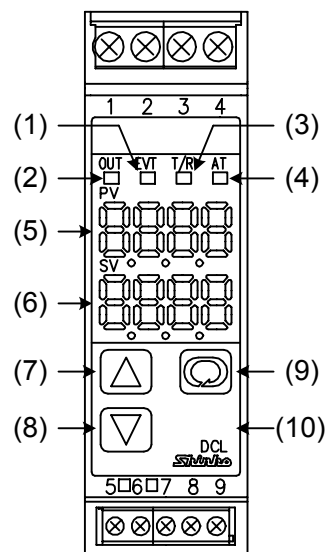

(Fig. 2-1)

3. Operation

The sensor input character and temperature unit are indicated on the PV display for approx. 3 seconds after the power is turned on, and the rated scale maximum value is indicated on the SV display. (Table 3.1-1)

(If the other value is set in the scaling high limit value, it is indicated on the SV display.)

During this time all outputs and the LED indicators are on their OFF status. After a while control starts indicating actual temperature on the PV display and setting value on the SV display.

(Table 3.1-1)

Input		Scale range		Resolution
M	K	0 to 1370°C	0 to 2500°F	1°C(°F)
		0.0 to 400.0°C	0.0 to 750.0°F	0.1°C(°F)
	J	0 to 1000°C	0 to 1800°F	1°C(°F)
	R	0 to 1760°C	0 to 3200°F	1°C(°F)
	S	0 to 1760°C	0 to 3200°F	1°C(°F)
	B	0 to 1820°C	0 to 3300°F	1°C(°F)
	E	0 to 800°C	0 to 1500°F	1°C(°F)
	T	-199.9 to 400.0°C	-199.9 to 750.0°F	0.1°C(°F)
	N	0 to 1300°C	0 to 2300°F	1°C(°F)
	PL-II	0 to 1390°C	0 to 2500°F	1°C(°F)
	C(W/Re5-26)	0 to 2315°C	0 to 4200°F	1°C(°F)
	Pt100	-199.9 to 850.0°C	-199.9 to 999.9°F	0.1°C(°F)
		-200 to 850°C	-300 to 1500°F	1°C(°F)
	JPt100	-199.9 to 500.0°C	-199.9 to 900.0°F	0.1°C(°F)
		-200 to 500°C	-300 to 900°F	1°C(°F)
	4 to 20mA	-1999 to 9999	*1, *2	1
0 to 20mA	-1999 to 9999	*1, *2	1	
0 to 1V	-1999 to 9999	*1	1	

*1: Scale range and decimal point place can be selected

*2: Needs to connect 50Ω shunt resistor (separately sold) between input terminals.

3.1 Operation flow chart

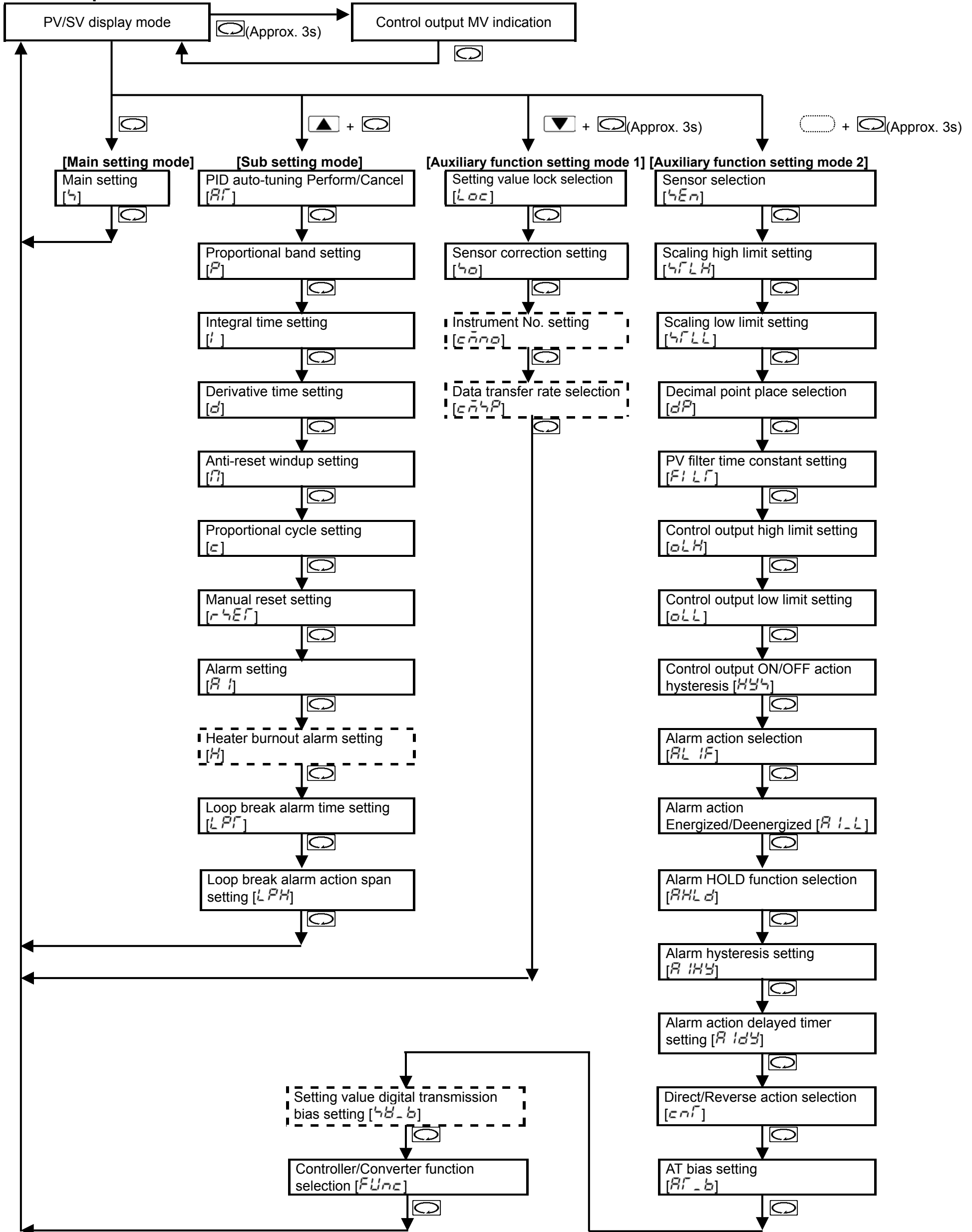

- ▲ + Enter: Press the Enter key while the ▲ key is being pressed.
 - ▼ + Enter (Approx. 3 seconds): Press the Enter key while the ▼ key is being pressed.
 - Dotted + Enter (Approx. 3 seconds): Press the Enter key while the Dotted key is being pressed.
- For setting and selecting in each setting mode, press ▲ or ▼ key.

3.2 Main setting mode

Character	Name, Description, Setting range	Initial value
↳	Main setting <ul style="list-style-type: none"> • Set the value for controlled objects. • Scaling low limit setting value to Scaling high limit setting value (Decimal point place follows the selection for DC current input) 	□/M: 0°C

3.3 Sub setting mode

Character	Name, Description, Setting range	Initial value
AF	PID auto-tuning Perform/Cancel <ul style="list-style-type: none"> • Performs PID auto-tuning. However when PID auto-tuning does not finish after 4 hours it started, PID auto-tuning is shut down compulsory. • PID cancellation : ---- • PID auto-tuning performing: AF 	----
P	Proportional band setting <ul style="list-style-type: none"> • Sets the proportional band. • ON/OFF action when setting the value to 0.0 • 0.0 to 110.0% 	2.5%
I	Integral time setting <ul style="list-style-type: none"> • Sets the integral time. • Setting the value to 0 disables this function. • This setting item is not indicated for ON/OFF action. • 0 to 1000 seconds 	200 seconds
D	Derivative time setting <ul style="list-style-type: none"> • Sets the derivative time. • Setting the value to 0 disables this function. • This setting item is not indicated for ON/OFF action. • 0 to 300 seconds 	50 seconds
N	Anti-reset windup setting <ul style="list-style-type: none"> • Sets anti-reset windup. • This setting item is indicated only for PID action. • 0 to 100% 	50%
C	Proportional cycle setting <ul style="list-style-type: none"> • Sets the proportional cycle value for the control output (OUT). • This setting item is not indicated for ON/OFF action or DC current output. • 1 to 120 seconds 	R/□: 30 seconds S/□: 3 seconds
rSET	Manual reset setting <ul style="list-style-type: none"> • Sets the resetting value manually. • This setting item is indicated only for P and PD action. • ±Proportional band converted value (In the case of DC voltage and current input, decimal point place follows the selection.) 	□/M: 0.0
Al	Alarm setting <ul style="list-style-type: none"> • Sets the action point for the alarm output. • Setting the value to 0 or 0.0 disables this function. (excluding Process high and Process low alarm) When Loop break alarm and Heater burnout alarm are applied together, the output is common. • This setting item is not indicated when “No alarm” action is selected in [Alarm action selection]. • See (Table 3.3-1). (In the case of DC voltage and DC current input, decimal point place follows the selection.) 	□/M: 0°C

Character	Name, Description, Setting range	Initial value
<i>H</i>	Heater burnout alarm setting <ul style="list-style-type: none"> • Sets the heater current value for Heater burnout alarm. • Setting the value to 0.0 disables this function. • Self-holding is not available for the alarm output. When alarm and Loop break alarm are applied together, the output is common. • This setting item is not indicated when [Option: W] is not added. • Rating 5A : 0.0 to 5.0A Rating 20A: 0.0 to 20.0A Rating 10A: 0.0 to 10.0A Rating 50A: 0.0 to 50.0A 	0.0A
<i>LPT</i>	Loop break alarm time setting <ul style="list-style-type: none"> • Sets the time to assess the Loop break alarm. • Setting the value to 0 disables this function. • When alarm and Heater burnout alarm are applied together, the output is common. • 0 to 200 minutes 	0 minutes
<i>LPH</i>	Loop break alarm action span setting <ul style="list-style-type: none"> • Sets the action span to assess the Loop break alarm. • Setting the value to 0 disables this function. • When alarm and Heater burnout alarm are applied together, the output is common. • Thermocouple and RTD input 0 to 150°C(°F) or 0.0 to 150.0°C(°F) • DC voltage and DC current input 0 to 1500 (Decimal point place follows the selection) 	□/M: 0°C

(Table 3.3-1)

Alarm action type	Setting range	
High limit alarm	-(Scaling span) to Scaling span	-side minimum setting value
Low limit alarm	-(Scaling span) to Scaling span	-199.9 or -1999
High/Low limits alarm	0 to Scaling span	
High/Low limit range alarm	0 to Scaling span	
Process high alarm	Scaling low limit setting value to high limit value	+side maximum setting value
Process low alarm	Scaling low limit setting value to high limit value	999.9 or 9999
High limit alarm w/standby	-(Scaling span) to Scaling span	
Low limit alarm w/standby	-(Scaling span) to Scaling span	
High/Low limits w/standby	0 to Scaling span	

3.4 Auxiliary function setting mode 1

Character	Name, Description, Setting range	Initial value
<i>Loc</i>	Setting value LOCK designation <ul style="list-style-type: none"> • Locks the setting value to prevent setting errors. The setting item to be locked is dependent on the designation. • PID auto-tuning cannot be carried out when Lock1 or Lock2 is selected. • - - - - (Unlock): All setting values can be changed. • <i>Lc1</i> (LOCK 1): None of setting values can be changed. • <i>Lc2</i> (LOCK 2): Only main setting mode can be changed. • <i>Lc3</i> (LOCK 3): All setting values can be changed except Controller/Converter function selection. However they return to their former value after power is turned off because they are not saved in the non-volatile memory. (Be sure to select LOCK 3 when using with PC-900 [SVTC attached]) 	Unlock

40	Sensor correction setting <ul style="list-style-type: none"> • Sets the sensor correction value of the sensor. • Thermocouple and RTD input: -100.0 to 100.0°C(°F) DC voltage and DC current input: -1000 to 1000 (Decimal point place follows the selection.) 	□/M: 0.0°C
cnno	Instrument number setting <ul style="list-style-type: none"> • Sets the instrument number individually to each instrument when connecting multiple instruments via serial communication. • This setting item is indicated only when [Option: C5] is added • 0 to 95 	0
cn4P	Data transfer rate selection <ul style="list-style-type: none"> • Selects the data transfer rate to meet the rate of host computer. • This setting item is indicated only when [Option: C5] is added • 2400bps: 24, 4800bps: 48, 9600bps: 96, 19200bps: 192 	9600bps

3.5 Auxiliary function setting mode 2

Character	Name, Description, Setting range	Initial value		
4En	<ul style="list-style-type: none"> • Selects the sensor type and temperature unit. 	K (0 to 1370°C)		
	Input		Character	
	K		0 to 1370°C : k C	0 to 2500°F : k F
			0.0 to 400.0°C : k .C	0.0 to 750.0°F : k .F
	J		0 to 1000°C : j C	0 to 1800°F : j F
	R		0 to 1760°C : r C	0 to 3200°F : r F
	S		0 to 1760°C : s C	0 to 3200°F : s F
	B		0 to 1820°C : b C	0 to 3300°F : b F
	E		0 to 800°C : e C	0 to 1500°F : e F
	T		-199.9 to 400.0°C: T C	-199.9 to 750.0°F: T F
	N		0 to 1300°C : n C	0 to 2300°F : n F
	PL-II		0 to 1390°C : PL2C	0 to 2500°F : PL2F
	C(W/Re5-26)		0 to 2315°C : c C	0 to 4200°F : c F
	Pt100		-199.9 to 850.0°C: Pt C	-199.9 to 999.9°F: Pt F
-200 to 850°C : Pt C		-300 to 1500°F: Pt F		
JPt100	-199.9 to 500.0°C: JPt C	-199.9 to 900.0°F: JPt F		
	-200 to 500°C : JPt C	-300 to 900°F : JPt F		
4 to 20mA	-1999 to 9999: 420A			
0 to 20mA	-1999 to 9999: 020A			
0 to 1V	-1999 to 9999: 0 1B			
4FLH	Scaling high limit setting <ul style="list-style-type: none"> • Sets the scaling high limit value. • Scaling low limit setting value to Input range maximum value (DC voltage and current input: Decimal point place follows the selection.) 	□/M: 1370°C		
4FLl	Scaling low limit setting <ul style="list-style-type: none"> • Sets the scaling low limit value. • Input range minimum value to Scaling high limit setting value (When DC voltage and DC current input, decimal point place follows the selection.) 	□/M: 0°C		
dP	Decimal point place selection <ul style="list-style-type: none"> • Selects the decimal point place. However, when thermocouple or RTD input is selected in sensor selection, this setting item is not indicated. • No decimal point to the 3rd digit after decimal point 	Decimal point omitted		

Character	Name, Description, Setting range	Initial value
<i>FILF</i>	PV filter time constant setting <ul style="list-style-type: none"> Sets the PV filter time constant. If the setting value is too large, it affects control result due to the response delay. 0.0 to 10.0 seconds 	0.0 seconds
<i>OLH</i>	Control output high limit setting <ul style="list-style-type: none"> Sets the control output high limit value. This setting item is not indicated when ON/OFF action. Control output low limit to 105% Setting greater than 100% is effective to DC current output type 	100%
<i>OLL</i>	Control output low limit setting <ul style="list-style-type: none"> Sets the control output low limit value. This setting item is not indicated during ON/OFF action. -5% to control output high limit Setting less than 0% is effective to DC current output type. 	0%
<i>HYS</i>	Control output ON/OFF action hysteresis setting <ul style="list-style-type: none"> Sets the ON/OFF action hysteresis for the control output. This setting item is indicated only for ON/OFF action (P=0) Thermocouple and RTD input: 0.1 to 100.0°C(°F) DC voltage and current input: 1 to 1000 (Decimal point place follows the selection.) 	□/M: 1.0°C
<i>ALIF</i>	Alarm action selection <ul style="list-style-type: none"> Selects alarm action type. <pre> No alarm : ---- High limit alarm : H Low limit alarm : L High/Low limits alarm : HL High/Low limit range alarm : uld Process high alarm : AH Process low alarm : rAL High limit alarm w/standby : H u Low limit alarm w/standby : L u High/Low limits alarm w/standby : HL u </pre>	No alarm
<i>ALL</i>	Alarm action Energized/Deenergized <ul style="list-style-type: none"> Selects alarm action Energized/Deenergized. This setting item is not indicated when “No alarm” action is selected in [Alarm action selection]. Energized: <i>non</i> Deenergized: <i>rEB</i> 	Energized
<i>AHLD</i>	Alarm HOLD function selection <ul style="list-style-type: none"> Selects whether alarm HOLD function is [Used] or not. If alarm HOLD function is set to used, once the alarm functions alarm output remains until the power is turned off. This setting item is not indicated when “No alarm” action is selected in [Alarm action selection]. Alarm HOLD [Not used]: <i>nonE</i> Alarm HOLD [Used] : <i>Hold</i> 	Alarm HOLD [Not used]
<i>AHS</i>	Alarm hysteresis setting <ul style="list-style-type: none"> Sets the alarm hysteresis. This setting item is not indicated when “No alarm” action is selected in [Alarm action selection]. Thermocouple and RTD input : 0.1 to 100.0°C(°F) DC voltage and DC current input: 1 to 1000 (Decimal point place follows the selection.) 	□/M: 1.0°C

<i>Al_d</i>	Alarm action delayed timer setting <ul style="list-style-type: none"> • Sets the alarm action delayed time. Alarm output activates when the setting time has passed after the input enters alarm output range. • This setting item is not indicated when “No alarm” action is selected in [Alarm action selection]. • 0 to 9999 seconds 	0 seconds
<i>cnf</i>	Direct/Reverse selection <ul style="list-style-type: none"> • Selects reverse (heating) or direct (cooling) control action. • Reverse (Heating) action: <i>HEAT</i> • Direct (Cooling) action : <i>COOL</i> 	Reverse (Heating) action
<i>At_b</i>	AT bias setting <ul style="list-style-type: none"> • Set the PID auto-tuning bias value. • This setting item is not indicated when DC voltage or current input is selected in [Sensor selection] and when action is not PID, either. • 0 to 50°C(0 to 100°F) or 0.0 to 50.0°C (0.0 to 100.0°F) 	20°C
<i>48_b</i>	Setting value digital transmission bias setting <ul style="list-style-type: none"> • The desired value is the value that adds the one set in the setting item to the received value by setting value digital transmission. • This setting item is indicated only when [Option: C5] is added. • $\pm 20\%$ of scaling span (DC voltage and DC current: Decimal point place follows the selection.) 	0
<i>FUnc</i>	Controller/ Converter function selection <ul style="list-style-type: none"> • Selects controller or converter function. • This setting item is indicated only when the control output is DC current output type. • Controller function: <i>cnfr</i>, Converter function: <i>cnbf</i> 	Controller function

Sensor correction function

This corrects the input value from the sensor. When a sensor cannot be set at a location where control is desired, the sensor measuring temperature may deviate from the temperature in the controlled location. When controlling with multiple controllers, the accuracy of the sensors has influence on the control. Therefore, sometimes the measuring temperature (input value) does not concur with the same setting value. In such case the control can be set at the desired temperature by shifting the input value of the sensors.

Loop break alarm

The alarm will be activated when the process variable (PV) does not rise as much value as the span or greater within the time it takes to assess the Loop break alarm after the manipulated variable has reached 0% or the output low limit value. When the control action is Direct (Cooling), the alarm acts conversely.

Energized/Deenergized function

[If temperature alarm action Energized is selected]

When the alarm output indicator is lit, the alarm output (between terminal 8 and 9) is conducted (ON).

When the alarm output indicator is unlit, the alarm output is not conducted (OFF).

[If temperature alarm action Deenergized is selected]

When the alarm output indicator is lit, the alarm output (between terminal 8 and 9) is not conducted (OFF).

When the alarm output indicator is unlit, the alarm output is conducted (ON).

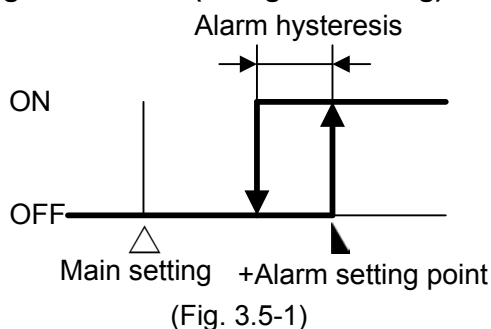

High limit alarm (Energized setting)

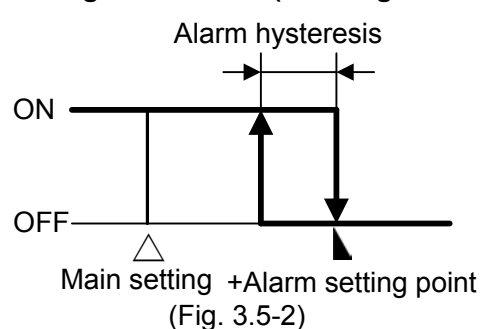

High limit alarm (Deenergize setting)





3.6 Control output manipulated variable indication

Name and Description
<p>Control output manipulated variable indication Press the  key for approx. 3 seconds during PV/SV indication mode. Keep pressing the  key until the output manipulated variable shows up, though the main setting mode appears during the process. (The control output manipulated variable is indicated on the SV display and the decimal point at the second digit blinks in 0.5 seconds cycle.) Pressing the  key again, it reverts to the PV/SV mode.</p>

4. Converter function

The converter function of this instrument converts each input (Thermocouple, RTD, DC voltage and DC current input) value to 4 to 20mA and outputs taking advantage of the control parameter of the controller. When this instrument is used as a converter, follow the process (1) to (7) described below. When the process (1) to (7) is finished, this can be used as a converter.

- (1): Wire and connect this instrument. (Power, Input and Output)
- (2): Turn the power of this instrument ON.
- (3): Call the "Auxiliary function setting mode 2" pressing the  and  key (for approx 3s).
- (4): Select the sensor type from "Sensor selection" (*SEN*).
- (5): Set the high limit of the value which is going to be converted from "Scaling high limit setting (*SHLH*)".
- (6): Set the low limit of the value which is going to be converted from "Scaling low limit setting (*SLHL*)".
- (7): Select converter (*CONV*) from "Control/ Converter" function selection (*FUNC*).

- **Outputs the input from scaling low limit setting value to high limit value in 4 to 20mA. The ratio of the changing quantity resolution is 1 to 1000 to scaling span.**
- **When functioning alarm action by Converter function, set the alarm action to Process alarm action.**

If converter function is selected from "Controller/Converter function selection" in auxiliary function setting mode 2, the parameter below is automatically set. (Table 4.1-1)

But this is applied only to the DC current output type.

(Table 4.1-1)

Setting item	Setting value	Setting item	Setting value
Main setting	Scaling low limit	Alarm setting	0
Proportional band setting	100.0%	Loop break alarm time setting	0 seconds
Integral time	0 seconds	Loop break alarm action span	0
Derivative time	0 seconds	Direct/Reverse action selection	Direct action
Manual reset setting	0.0		

• How to fine-tune DC current output (4 to 20mA)

Carry out zero, span adjustment from zero side several times.

Carry out adjustment set by manual reset.

- (1) Input the value so that the same scaling low limit value may be indicated on the PV display.
- (2) Adjust the value so that the DC current output value may become 4mA by increasing and decreasing manual reset value. Output decreases when manual reset value is set to + side, on the other hand output increases when it is set to – side.

Carry out adjustment of span in the proportional band

- (1) Input the value so that the same scaling high limit value may be indicated on the PV display.
- (2) Adjust the value so that the DC current output value may become 20mA by increasing and decreasing manual reset value. Output decreases when proportional band value is set to + side, on the other hand output increases when it is set to – side.



Caution

When shifting from converter function to controller function, the control parameter and values set by converter function are held as they are even if the function is switched to controller function.

So, correct the control parameter and values set by converter function to the value necessary to the controller function after switching to the controller function.

5. Running

When mounting and wiring to the control panel (DIN rail) are finished, running starts following the next procedure.

(1) Turn the power supply to the DCL-33A ON.

For approx. 3s after power on, the character of the sensor type and temperature unit are indicated on the PV display, and the rated maximum value is indicated on the SV display. See [Table 3.1-1]. (If any other value is set at the main setting value high limit setting, SV display indicates it.)

During this time, all outputs and LED indicators are in their OFF status.

After that PV display indicates actual temperature and SV display indicates the main setting value.

(2) Input the setting value.

Input each setting value referring to "3. Operation".

(3) Turn the load circuit power ON.

Starts control action so as to keep temperature of the controlled object at the main setting value.

6. Other functions

(1) Power failure countermeasure.

Backs up the setting data in non-volatile IC memory.

(2) Self diagnosis

The CPU is monitored by a watchdog timer and when any abnormal status is found on the CPU, the controller is switched to warm-up status.

(3) Automatic cold junction temperature compensation (Only thermocouple input)

Detects the temperature at the connection terminal between thermocouple and instrument and keeps it on the same status at which the reference junction is located at 0°C(32°F).

(4) Sensor burnout (Burnout)

When thermocouple or RTD input is burnt out, control output is turned OFF (DC current output type: control output low limit) and " _ _ _ _ " blinks on the PV display.

When DC voltage and DC current input are burnt out, the status is as follows.

When DC current input (4 to 20mA) and DC voltage input (1 to 5V) are burnt out " _ _ _ _ " blinks on the PV display.

When DC voltage input (0 to 1V) is burnt out, " _ _ _ _ " blinks on the PV display.

When DC current input (0 to 20mA) is burnt out, the same value at 0mA is indicated.

When DC current input (0 to 10V) is burnt out, a value close to 0V is indicated.

(5) Input burnout indication

Thermocouple, RTD input

If the PV value exceeds [input range high limit + (50°C or 100°F)], " _ _ _ _ " blinks on the PV display and control output is turned OFF (DC current output type: control output low limit setting value).

However, in the case of the range with a decimal point when PV exceeds 999.9°C(°F), " _ _ _ _ " blinks and control is carried out until the value becomes [Input range high limit + (50°C or 100°F)] or greater.

DC voltage and current input

If the PV value exceeds [scaling high limit value + (scaling span x 10% or greater)], " _ _ _ _ " blinks on the PV display and the control output is turned OFF (DC current output type: control output low limit setting value).

However, when PV value exceeds 9999, " _ _ _ _ " blinks on the PV display and control is carried out until the value becomes [Scaling high limit + (scaling span x 10%)] or greater.

Thermocouple input

If the PV value exceeds [input range high limit - (50°C or 100°F)], " _ _ _ _ " blinks on the PV display and control output is turned OFF (DC current output type: control output low limit setting value).

However, in the case of the range with a decimal point when PV exceeds -199.9°C(°F), " _ _ _ _ " blinks and control is carried out until the value becomes [-199.9- (50°C or 100°F)] or less.

RTD input

If the PV value exceeds [Input range low limit - (input span x 1)] " _ _ _ _ " blinks on the PV display and control output is turned OFF (DC current output type: control output low limit setting value).

However, in the case of the range with a decimal point when PV exceeds -199.9°C(°F), " _ _ _ _ " blinks and control is carried out until the value becomes [-199.9- (input span x 1%)] or less.

DC voltage and current input

If the PV value exceeds [Scaling low limit value - (scaling span x 1%)] " _ _ _ _ " blinks on the PV display and control output is turned OFF (DC current output type: control output low limit setting value).

However if the PV value exceeds -1999, " _ _ _ _ " blinks on the PV display and control is carried out until the value becomes [Scaling low limit value setting value - (scaling span x 1%)] or less.

7. Action explanations

7.1 Standard action

Action	Heating (reverse)action	Cooling (direct)action
Control action		
Relay contact output	<p>Cycle action according to deviation</p>	<p>Cycle action according to deviation</p>
Non-contact voltage output	<p>Cycle action according to deviation</p>	<p>Cycle action according to deviation</p>
Current output	<p>Cycle action according to deviation</p>	<p>Cycle action according to deviation</p>
Indicator (OUT) Green		

part: Acts ON or OFF

7.2 ON/OFF action

Action	Heating (reverse) action	Cooling (direct) action
Control action		
Relay contact output		
Non-contact voltage output		
Current output		
Indicator(OUT) Green		

part: Acts ON or OFF.

7.3 Alarm action

	High limit alarm	Low limit alarm	High/Low limits alarm
Alarm action			
Alarm output	+ side	+ side	
	High/Low limit range alarm	Process high alarm	Process low alarm
Alarm action			
Alarm output			
	High limit alarm with standby	Low limit alarm with standby	High/Low limit range alarm
Alarm action			
Alarm output	+ side	+ side	

:Event (EVT) output terminal 8 and 9 is ON

:Event (EVT) output terminal 8 and 9 is ON or OFF

:Event (EVT) output terminal 8 and 9 is OFF

: Standby function works here.

Event (EVT) output indicator lights when output terminal between 8 and 9 is ON, goes out when OFF

7.4 Heater burnout alarm action

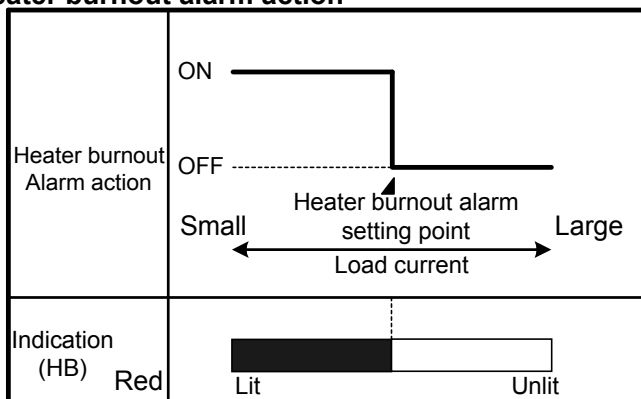

:Event(EVT)output terminal between 8 and 9 is ON

:Event(EVT)output terminal between 8 and 9 is OFF

Event (EVT) output indicator lights when output terminal between 8 and 9 is ON, goes out when OFF

8. PID auto-tuning of the DCL-33A

In order to decide each P, I, D value and ARW automatically, this system gives a fluctuation to the controlled object to get a optimal value.

3 types of fluctuation below are automatically selected.

[When the difference between setting value and processing temperature is large in rising]

When AT bias is set to 20°C(°F), a fluctuation is given at the temperature 20°C(°F) lower than the setting value.

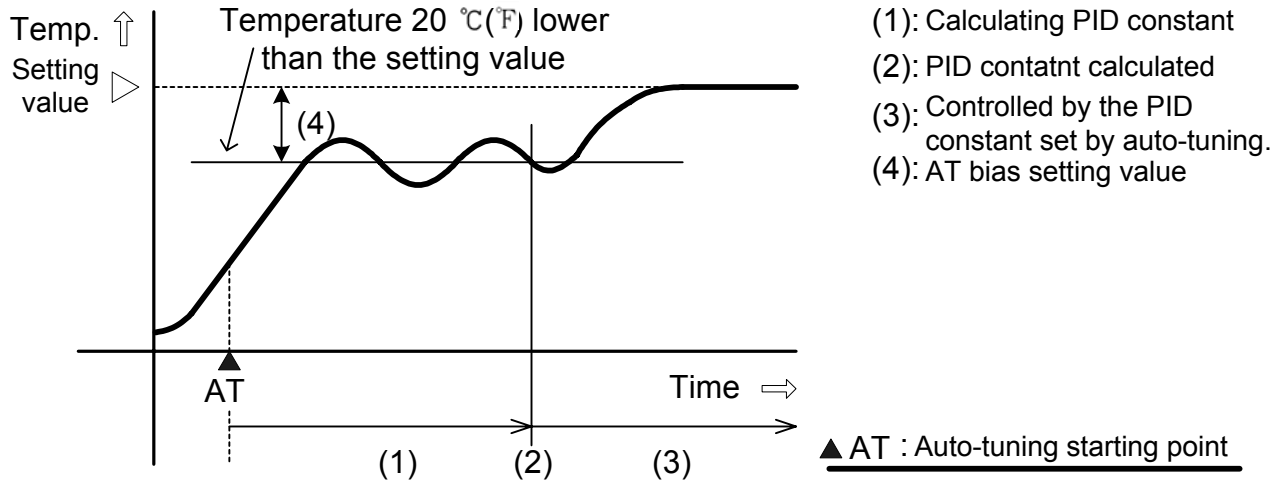

[When control is stable]

A fluctuation is given at the setting value.

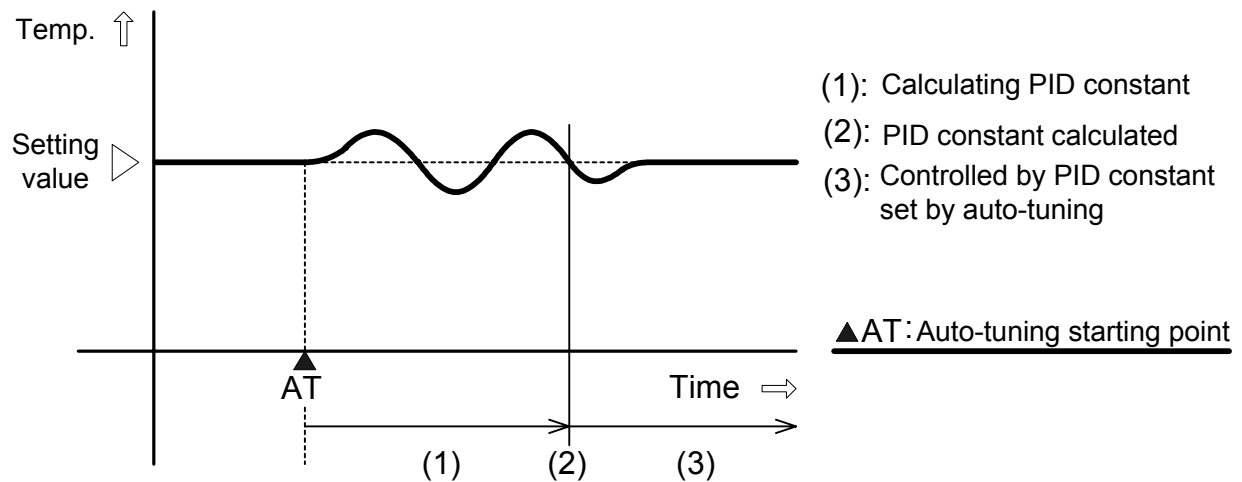

[When the difference between the setting value and processing temperature is large when temperature falls]

When AT bias is set to 20°C(°F), a fluctuation is given at the temperature 20°C(°F) higher than the setting value.

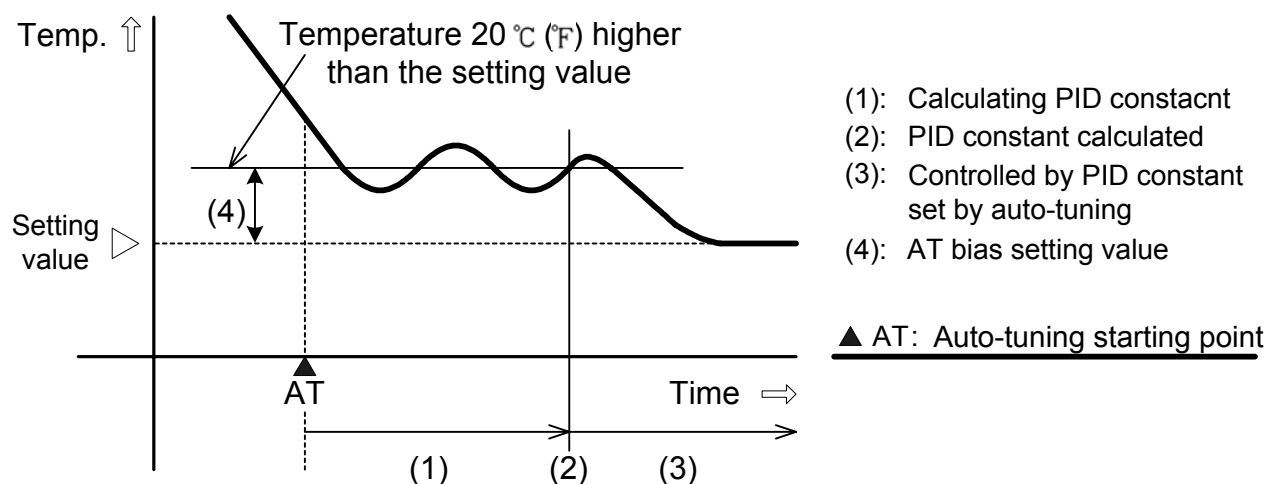

9. Mounting to the control panel

9.1 Site selection

[Use this instrument in the following environment (IEC61010-1)]

- Overvoltage category II, Pollution degree 2

[Use this instrument under the conditions below.]

- A minimum of dust, and an absence of corrosive gasses
- No flammable, explosive gasses
- Few mechanical vibrations or shocks
- No exposure to direct sunlight, an ambient temperature of 0 to 50°C (32 to 122°F)
- An ambient non-condensing humidity of 35 to 85%RH or less
- The units away from large capacity electromagnetic switches or cables
- No water, oil or chemicals or where the vapors of these substances can come into direct contact with the unit.

9.2 External dimension

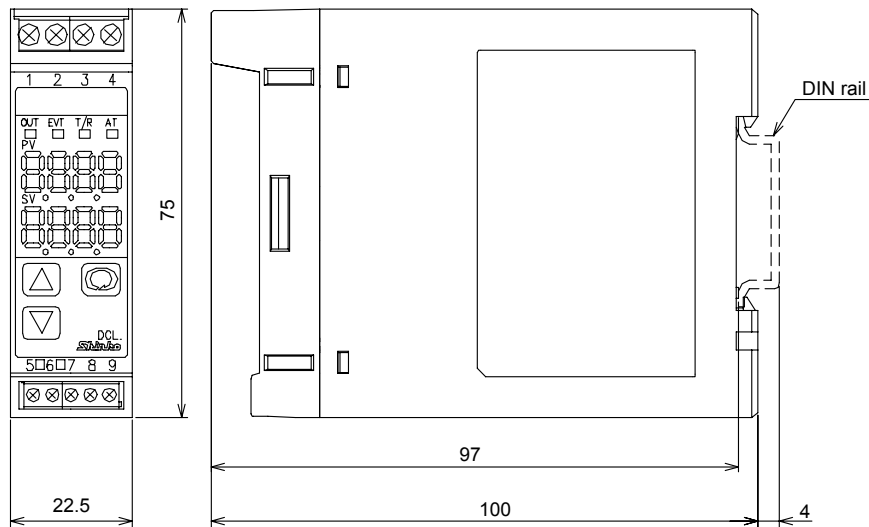

(Fig.9.2-1)

9.3 CT (Current transformer) External dimension

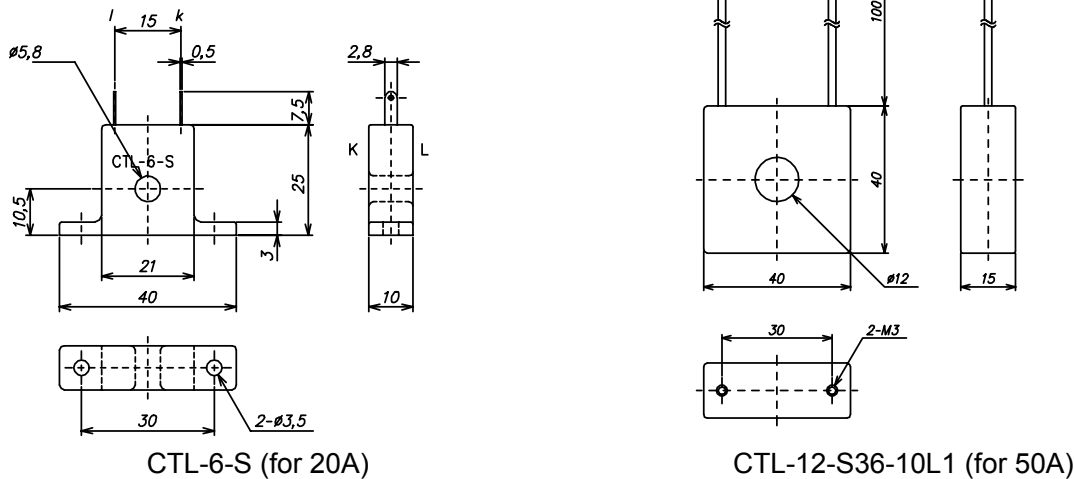

(Fig.9.3-1)

9.4 Mounting to DIN rail



Caution

Mount the DIN rail horizontally.

When DIN rail is mounted vertically, be sure to use commercially available fastening plates at the end of DCL-33A. Mount the DCL-33A to the DIN rail so that the DCL-33A cannot move.

However, if the DIN rail is mounted horizontally in a position susceptible to vibration or shock, the fastening plates must be used as well.

* **Recommended fastening plate**

Omron corporation	End plate	PFP-M
IDEC corporation	DIN rail stops	BNL6, BNL8
Matsushita electric works, LTD	Fastening plate	ATA4806

- (1) Hook (1) of DCL-33A on the upper side of the DIN rail. (Fig. 9.4-1)
- (2) Making the (1) part of the DCL-33A as a support, fit the lower part of the DCL-33A to the DIN rail. DCL-33A will be completely fixed to DIN rail with a “Click” sound. (Fig.9.4-1)

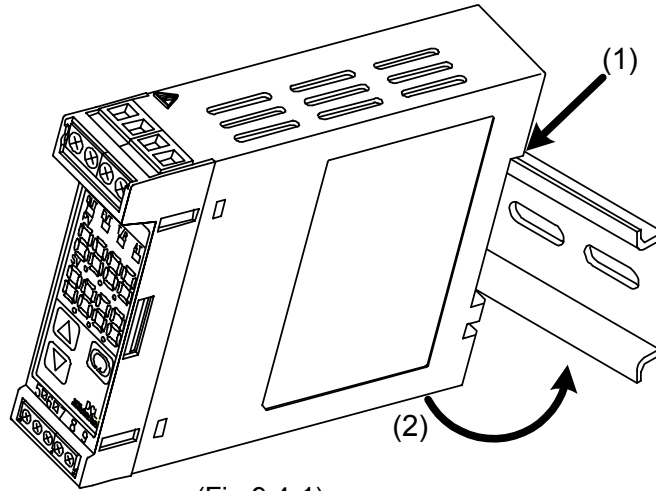

(Fig.9.4-1)

10. Wiring



Warning

Turn the power supplied to the instrument **OFF** before wiring or checking.
Working or touching the terminal with the power switched **ON** may result in an Electric Shock which could cause severe injury or death.



Caution

- Do not drop wire chips into DCL-33A when wiring, because they could cause fire, malfunction and trouble
- Insert the connecting cable into the designated connector securely to prevent malfunction, or it may cause malfunction due to imperfect contact.
- Connect the AC power wiring to the designated terminal as is written in this Instruction manual, or it may burn and damage DCL-33A.
- Tighten the terminal screw with the specified torque, or damage the terminal screw and deform the case.
- Use thermocouple and compensating lead wire that fit sensor input specification of this unit.
- Use 3-wire RTD that fits sensor input specification of this unit.
- Do not confuse the polarity when using DC voltage and current input in the case 24Vdc is used.
- Keep input wire (Thermocouple, RTD) away from power source and load wire when wiring.
- To prevent the unit from harmful effects of the unexpected level noise, it is recommended that a surge absorber to be installed between the electromagnetic switch coils.
- This unit has neither built-in power switch nor fuse. Therefore it is necessary to install them in the circuit near the external unit.

(Recommended fuse: Rated voltage 250Vac, Rated current: 2A, Fuse type: Time-lag fuse)

*** Note**

Tighten the terminal screw properly referring to the table below.

Terminal screw	Terminal No.	Torque
M2.6	(1) to (4)	Max. 0.5N·m
M2.0	(5) to (9)	Max. 0.25N·m

• Terminal arrangement

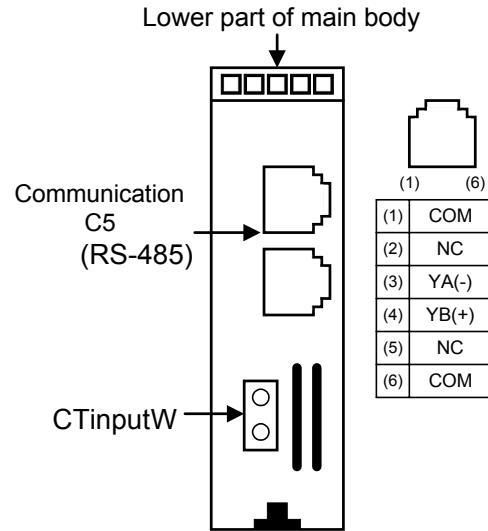
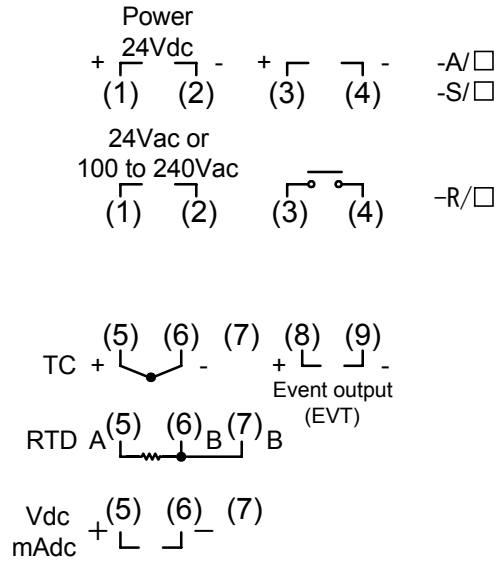

(Fig.10-1)

- R/□: Relay contact output
- S/□: Non-contact DC voltage output
- A/□: DC current output
- Event output (Open collector output)
 Outputs when alarm, Loop break alarm or Heater burnout alarm [Option] is ON.

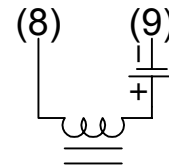

(Fig.10-2)

• Option: Heater burnout alarm output

This alarm is not available for detecting current under phase control.
 Use the current transformer (CT) provided, and pass a lead wire of the heater circuit into a hole of the CT.
 When wiring, keep the CT wire away from any AC source or load wires to avoid the external interference.

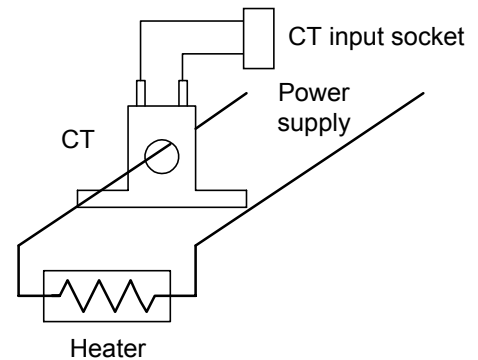

(Fig.10-3)

11. Specifications

11.1 Standard specifications

Model name	DIN rail mounting type indicating controller	
Mounting method	DIN rail mounting method	
Setting method	Membrane sheet key	
Display	PV display: Red LED 4-digit	Character size: 7.5 x 4.1mm (H x W)
	SV display: Green LED 4-digit	Character size 7.5 x 4.1mm (H x W)

- Input** Thermocouple: K, J, R, S, E, T, N, PL-II, C (W/Re5-26) External resistance: 100Ω or less
 B thermocouple: External resistance: 40Ω or less
- RTD : Pt100, JPt100 3-wire system
 Allowable input wire resistance (10Ω or less per wire)
- DC current : 0 to 20mAdc, 4 to 20mA input impedance 50Ω
 [Connect 50Ω shunt resistor (sold separately) between input terminal (5) and (6).]
 Allowable input current: 50mA or less
- DC voltage : 0 to 1Vdc
 Input impedance: 1MΩ or greater
 Allowable input voltage: 5V or less
 Allowable signal source resistance
 : 2kΩ or less
- Accuracy (Indicating • Setting)
 Thermocouple input: Within $\pm 0.2\%$ of input span ± 1 digit or $\pm 2^{\circ}\text{C}$ (4°F) whichever is greater
 R, S input 0 to 200°C(0 to 400°F): Within $\pm 6^{\circ}\text{C}$ (12°F)
 B input 0 to 300°C(0 to 600°F): Accuracy is not guaranteed.
 RTD input: Within $\pm 0.1\%$ of input span ± 1 digit or within $\pm 1^{\circ}\text{C}$ (2°F) whichever is greater.
 DC voltage input : Within $\pm 0.2\%$ of input span ± 1 digit
 DC current input : Within $\pm 0.2\%$ of input span ± 1 digit
 Input sampling period : 0.25 seconds
- Control** Control action
- PID action (with auto-tuning function)
 - PI action : When derivative time is set to 0
 - PD action (with manual reset function): When integral time is set to 0
 - P action (with manual reset function) : When derivative and integral time are set to 0
 - ON/OFF action : When proportional band is set to 0
 Proportional band: 0.0 to 110.0% [Factory adjusted as 2.5%]
 (ON/OFF action when set to 0.0)
- Integral time : 0 to 1000 seconds (Off when set to 0) [Factory adjusted as 200 seconds]
 Derivative time : 0 to 300 seconds (Off when set to 0)[Factory adjusted as 50 seconds]
 Proportional cycle: 1 to 120 seconds [Factory adjusted as -R/30s, -S/3s, -A/] Not available]
 ARW : 0 to 100% [Factory adjusted as 50%]
 Manual reset : \pm Proportional band converted value [Factory adjusted as 0.0]
 Output limit : 0 to 100% (DC current output type: -5 to 105%)
 (Not available for ON/OFF action)
 [Factory adjusted as control output low limit setting value 0%
 control output high limit setting value 100%]
 Hysteresis : Thermocouple and RTD input: 0.1 to 100.0°C(°F)
 [Factory adjusted as 1.0°C]
 DC voltage and current input: 1 to 1000
 (Decimal point place follows the selection.)
 [Factory adjusted as 10]
- Control output (OUT)
- Relay contact: 1a Control capacity 250Vac 3A (Resistive load)
 250Vac 1A (Inductive load COS ϕ =0.4)
 Electric life 100,000 times
 - Non-contact voltage (for SSR drive): 12 $^{+2}_{-0}$ Vdc Max. 40mA (Short-circuit protected)
 Shinko SSR (SA-200 series): 4 units connectable parallel
 - DC current: 4 to 20mAdc, Load resistance: Max. 550Ω
 Output accuracy: Within $\pm 0.3\%$ of output span
 Resolution : 12000
- Alarm** Alarm (EVT) output (Common output with Loop break alarm, Heater burnout alarm [Option: W])
 When input exceeds the range in \pm deviation setting (excluding Process alarm) to the main
 setting, alarm (EVT) turns ON or OFF (High/Low limit range alarm), and when Deenergized
 is selected in Energized/Deenergized selection, alarm (EVT) is activated conversely.

Setting accuracy: The same as indicating accuracy

Action: ON/OFF action

Hysteresis: Thermocouple and RTD input: 0.1 to 100.0°C(°F) [Factory adjusted as 1.0°C]

DC voltage and current input: 1 to 1000 [Factory adjusted as 10]

(Decimal point place follows the selection.)

Output: Open collector Control capacity 24Vdc 0.1A (Max.)

Alarm (EVT) output action: Alarm action is selectable from below by front key operation.

One alarm is selectable from High limit, Low limit, High/Low limits, High/Low limit range, Process high, Process low, High limit w/standby, Low limit w/standby, High/Low limits w/standby and No alarm action [Factory adjusted as No alarm action]

Energized/Deenergized : Alarm (EVT) output Energized/Deenergized can be selected. [Factory adjusted as Energized]

	Energized	Deenergized
Red (EVT) LED	Lights	Lights
Alarm output	ON	OFF

Alarm HOLD function selection: Once the alarm is activated, alarm output is remains constant until power is turned off.

[Factory adjusted as: Alarm holding function Not used]

Loop break alarm (EVT) output

(Common output with Alarm, Heater burnout alarm [Option: W])

Detects heater burnout, sensor burnout, and abnormality at operation end.

Setting range: Loop break alarm time setting: 0 to 200 minutes

[Factory adjusted as 0 minutes]

Loop break alarm action span setting

Thermocouple and RTD input: 0 to 150°C(°F) or 0.0 to 150.0°C(°F)

[Factory adjusted as 0°C]

DC voltage and current input: 0 to 1500

(Decimal point place follows the selection.) [Factory adjusted as 0]

Output: Open collector Control capacity 24Vdc 0.1A (Max.)

Converter function

See "4. Converter function"

Isolation • Dielectric strength Circuit isolation structure

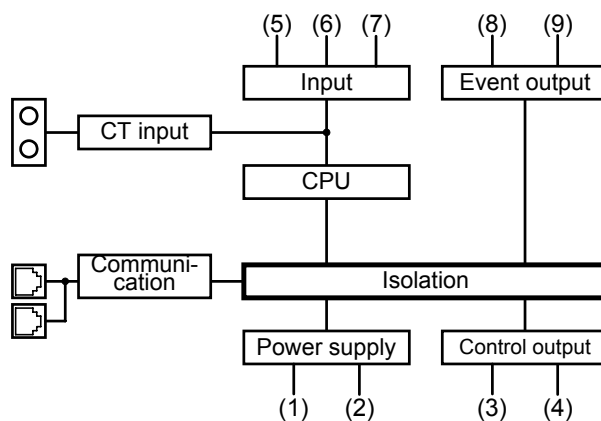

* When control output is non-contact voltage or DC current, between control output and communication is not isolated.

Isolated resistance: 10MΩ or greater at 500Vdc except the above

Dielectric strength : 1.5kVac for 1 minute between input terminal and power terminal

1.5kVac for 1 minute between output terminal and power terminal

Power consumption	Approx. 6VA
Ambient temperature	0 to 50°C
Ambient humidity	35 to 85%RH (No condensing)
Weight	Approx. 150g
External dimension	22.5 x 75 x 100mm (W x H x D)
Material	Case: Flame resistant resin

Color	Case: Light gray
Attached function	Sensor correction, Setting value lock, Power failure countermeasure, Self-diagnosis, Automatic cold junction compensation, Burnout, Input burnout
Accessories	Instruction manual: 1 copy
	When [Option: W] is added
	Wire harness 3m : 1 set
	W (5A), W (10A), W (20A): Current transformer: CTL-6S 1 set
	W (50A) : Current transformer: CTL-12-S36-10L1 1 set

11.2 Optional specifications

Heater burnout alarm output (W)

Watches the heater current with CT (Current transformer) and detects the burnout.

When this option is added, alarm output and Loop break alarm will be common.

This option cannot be applied to the current output type.

Rating	: 5A [W (5A)], 10A [W (10A)], 20A [W (20A)], 50A [W (50A)] (Must be designated)		
Setting range	5A [W (5A)]	0.0 to 5.0A	(Off when set to 0.0)
	10A [W (10A)]	0.0 to 10.0A	(Off when set to 0.0)
	20A [W (20A)]	0.0 to 20.0A	(Off when set to 0.0)
	50A [W (50A)]	0.0 to 50.0A	(Off when set to 0.0)
Setting accuracy	: $\pm 5\%$ of the rated value		
Action	: ON/OFF action		
Output	: Open collector		
	Control capacity	24Vdc 0.1A (Max.)	

Serial communication (C5)

Operates the following from the external computer.

- (1) Reading and setting of main setting value, PID and each setting value
- (2) Reading of input value and action status
- (3) Function change

Communication circuit: Based on EIA RS-485

Communication method: Half-duplex start-stop synchronous

Data transfer rate: 2400, 4800, 9600 or 19200bps is selectable by key operation.

Data format: Start bit-----1
Data bit-----7
Parity----- Even
Stop bit-----1

Digital external setting: Receives digital setting value from the PC-900 series [Option: SVTC]

Select Lock3 from the setting value Lock selection.

Setting instrument number is not required.

When data from PC-900 series exceeds scaling high limit or scaling low limit setting value, this instrument ignores the value and carries out control at the scaling high limit or scaling low limit setting value.

When the value is set from SVTC bias setting of DCL-33A, the desired value is the one that adds SVTC bias value to the received value from PC-900 series by external digital setting.

However, if the added value exceeds scaling high limit setting value or scaling low limit value of the DCL-33A, it ignores the value and carries out control at the scaling high limit setting value or scaling low limit setting value.

12. Troubleshooting

If any malfunctions occur, refer to the following items after checking the power supply and wiring.

Indication

Phenomenon	Presumed cause and solution
“----” is blinking on the PV display.	<ul style="list-style-type: none"> • Sensor (Thermocouple, RTD and DC voltage [0 to 1Vdc] input) is burnt out. Change the sensor for new one. • The lead wire of the sensor (Thermocouple, RTD and DC voltage [0 to 1Vdc] input) is not securely connected. Connect it to the terminal properly.
The indication on the PV display does not change.	<ul style="list-style-type: none"> • Sensor (DC current [0 to 20mAdc] and DC voltage [0 to 10Vdc]) is burnt out. Change the sensor for the new one. • The lead wire of the sensor (DC current [0 to 20mAdc] and DC voltage [0 to 10Vdc] is not securely connected to the terminal. Connect the sensor lead wire securely to the instrument terminal.
“----” is blinking on the PV display.	<ul style="list-style-type: none"> • Sensor (DC current [4 to 20mAdc] and DC voltage[1 to 5Vdc] input) is burnt out. Change the sensor for the new one. • The sensor lead wire is not securely connected to the terminal (DC current 4 to 20mAdc) and DC voltage [1 to 5Vdc] Connect the sensor lead wire securely to the terminal of the instrument.
The indication on the PV display is abnormal or unstable.	<ul style="list-style-type: none"> • Designation of the sensor (input) is incorrect. Set the correct sensor (input). • The polarity of the sensor input is incorrect. Wire it correctly. • Temperature unit (°C/°F) is mistaken. Set the correct unit. • AC is leaking from controlled object to thermocouple or RTD. Keep AC from leaking into the controlled object.
“Err !” is indicated on the PV display.	<ul style="list-style-type: none"> • Internal memory is out of order. Please contact our sales branch or the shop where you purchased this unit.

Key operation

Phenomenon	Presumed cause and solution
<ul style="list-style-type: none"> • Setting values do not change even if the ▲ or ▼ key is pressed during setting mode 	<ul style="list-style-type: none"> • Mode1 or mode 2 is selected in setting value lock selection. Cancel the Lock mode. • PID auto-tuning is performing. Cancel PID auto-tuning.
<ul style="list-style-type: none"> • Unable to set the value beyond or below scaling high limit or low limit within the rated scale range even if the ▲ or ▼ key is pressed. 	<ul style="list-style-type: none"> • The value of scaling high limit setting or low limit setting in auxiliary function setting mode 2 is set to still one. Set the proper value.

- If you have any inquiries, please consult our agency or the shop where you purchased the unit.

SHINKO TECHNOS CO.,LTD. OVERSEAS DIVISION

Reg. Office : 2-48, 1-Chome, Ina, Minoo, Osaka, Japan

Mail Address: P.O.Box 17, Minoo, Osaka, Japan

URL : <http://www.shinko-technos.co.jp>

E-mail : overseas@shinko-technos.co.jp

Tel : 81-727-21-2781

Fax: 81-727-24-1760