

sanitary pressure gauges DS 2.5", 4" (63-100mm)

SP

- AISI 316L st.st. wetted parts
- Ra $\leq 0,8\mu\text{m}$ - 32 μin (150 Grit) finishing
- Reduced temperature error
- C.I.P. and S.I.P execution
- Autoclavable execution (on request)
- 1"1/2 or 2" CLAMP process connection



74-02
Autorization NO. 597



These instruments are designed for Sanitary, Food Process and Pharmaceutical Industries in compliance with standard n.74-02 of 3-A (Sanitary Standards Symbol Administrative Council). The absence of interstices and the mirror finishing of the components assure the best hygiene. The combination of pressure gauge and diaphragm seal allow to reduce the inner volumes and temperature error. To reduce the effects of severe working conditions like vibrations and pulsations, the instruments can be filled.

Standard model

Design: ASME B40.1

Ranges: from 0...15 psi to 0...600 psi; (from 0...1 bar to 0...40 bar or equivalent units).

Accuracy: grade A as per ASME B40.1 (2-1-2%) for DS 4" (100mm); grade B as per ASME B40.1 (3-2-3%) for DS 2.5" (63mm);

Ambient temperature: -13...+149 °F (-25...+65 °C).

Process temperature: -4...+212 °F (-20...+100 °C).

Max 266°F (130 °C) for 1 hour during cleaning stage (C.I.P.)¹ and sterilization (S.I.P.)².

Working pressure (referred to the full scale value): max 75%.

Over pressure limit: not available.

Seal fill: mineral oil (FDA approved) for food service.

Protection: IP 67.

Process connection: AISI 316L st.st. with Ra $\leq 0,8\mu\text{m}$ - 32 μin (150 Grit) finishing with:

1" 1/2 CLAMP (ISO 2852)

2" CLAMP (ISO 2852)

Diaphragm: AISI 316L st.st. .

Welding: AISI 316L TIG.

Case: electro polished AISI 304 st.st.

Ring: polished AISI 304 st.st., crimped.

Window: plastic.

Dial: aluminium, white with black markings.

Pointer: aluminium black anodized.

Fillable liquid

This version can be autoclaved and sterilized at a max temperature of 304°F (150 °C) for 1 hour.

Window: Polysulfone.

Gasket: silicon rubber.

Blow out vent and filling plug: VITON.

Other features: as standard model.

Liquid filled

Case fill: glycerine 99,5% (USP, E.P. e F.U.) for food service.

Ambient temperature: +59...+149 °F (+15...+65 °C).

Other features: as standard model.

1) C.I.P. = Cleaned In Place

2) S.I.P. = Steamed In Place

sanitary pressure gauges

DS 2.5", 4" (63-100mm)

SP

REV.A2 E 06/05

www.nuovafima.com

UPDATED DATA SHEETS ARE AVAILABLE AT ANY TIME.

IN ORDER TO IMPROVE THEIR PRODUCTION, MESSRS. NUOVA FIMA RESERVE THE RIGHT TO THEMSELVES TO MAKE ALL THE MODIFICATIONS THAT THEY DEEM INDISPENSABLE AT ANY TIME.

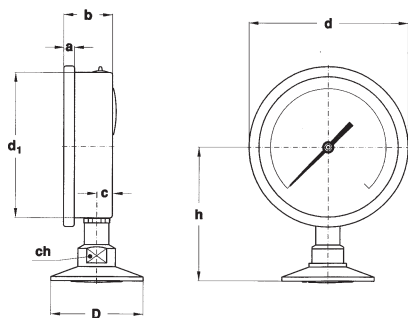

LOWER CONNECTION MOUNTING

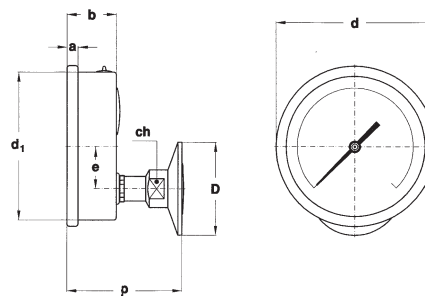

DS 4" (100mm) - BACK CONNECTION MOUNTING

DS	1" 1/2 ^D	2"	a	b	c	d	d ₁	e	h	p	ch	Weight (1)
2.5" (63 mm)	1.98"	2.51"	0.21"	1.10"	0.39"	2.67"	2.46"		3.11"		0.86"	0.61 lbs
4" (100 mm)	1.98"	2.51"	0.29"	1.33"	0.43"	4.33"	0.39"	1.14"	3.64"	3.12"	0.86"	0.92 lbs

(dimensioni : inches)

(1) add 0.26 lbs (0,12 kg) for DS 2.5" (63 mm) and 0.66 lbs (0,30 kg) for DS 4" (100 mm), when filled

RANGES - "C" = DS 2.5" (63mm); "E" = DS 4" (100mm).

PRESSURE

TAB. 1

RANGE	bar
0...1 (1)	E
0...1,6 (1)	E
0...2,5	C-E
0...4	C-E
0...6	C-E
0...10	C-E
0...16	C-E
0...25	C-E
0...40	C-E
0...60	E

TAB. 2

RANGE	psi ext.	bar int.
0...15 (1)	E	
0...30	C-E	
0...60	C-E	
0...100	C-E	
0...160	C-E	
0...200	C-E	
0...300	C-E	
0...400	C-E	
0...600	C-E	

VACUUM & COMPOUND

TAB. 3

RANGE	bar
-1...0 (1)	E
-1...0,6 (1)	E
-1...1,5	C-E
-1...3	C-E
-1...5	C-E
-1...9	C-E
-1...15	C-E

TAB. 4

RANGE (2)	psi ext.	bar int.
-30...0 (1)	E	
-30...15 (1)	E	
-30...30	C-E	
-30...60	C-E	
-30...100	C-E	
-30...150	C-E	
-30...300	C-E	

(1) available only for 2" CLAMP connection

(2) vacuum unit of measurement: "inHg"

(1) available only for 2" CLAMP connection

OPTIONS

Model	Fillable	Filled
Autoclavable execution	◆	
Accuracy ± 1,6%	◆	◆
Polycarbonate window	◆	◆

"HOW TO ORDER" SEQUENCE

Section / Model / Case / Mounting / Diameter / Special version / Range / Process connection / Options

