

TX QuickStart

Infrared Sensor

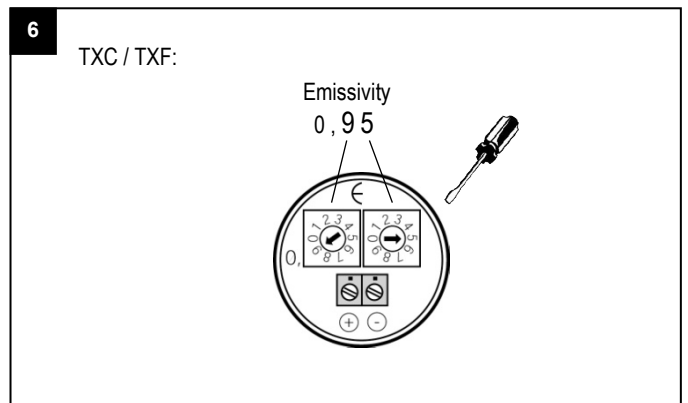

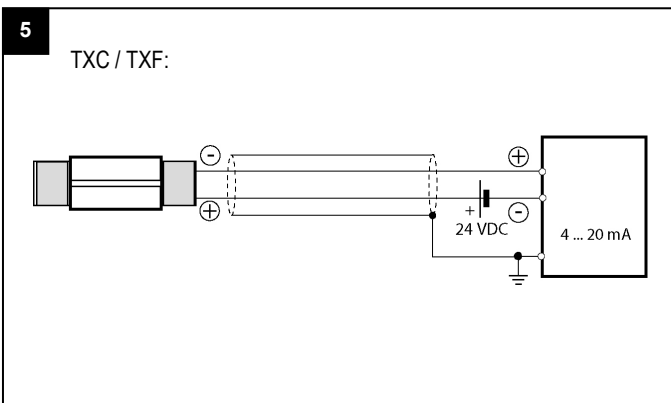
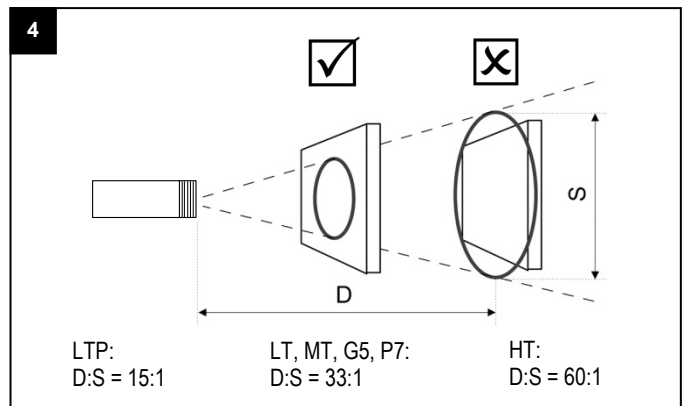
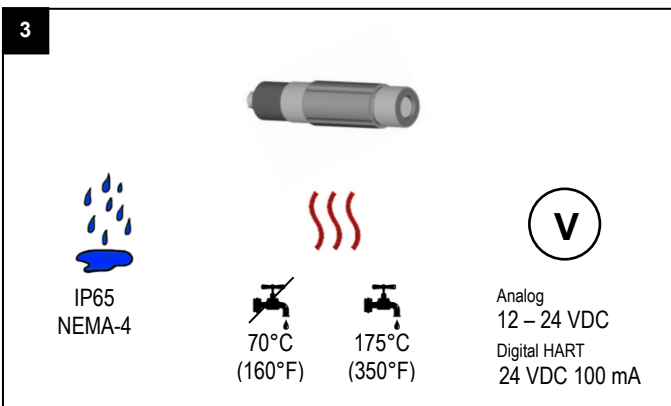
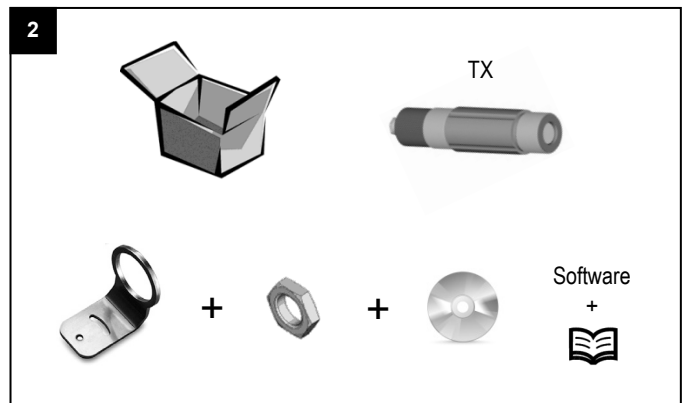
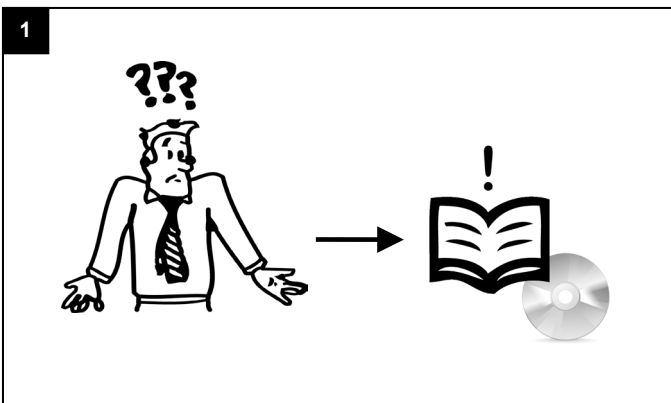
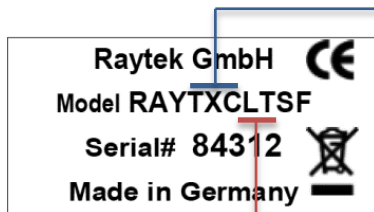
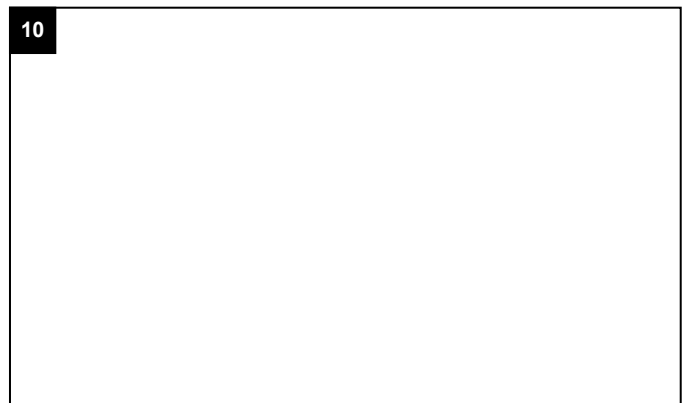
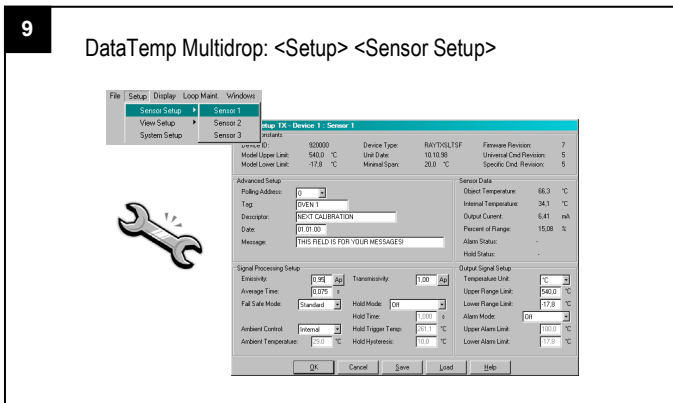
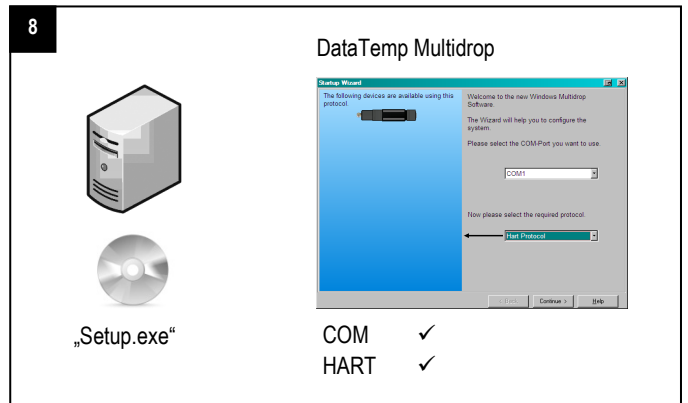
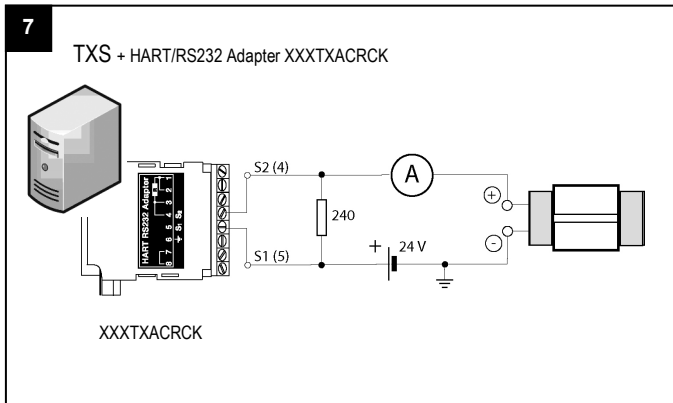

	TXC	TXF	
LTP	-18...500°C	0...1000°F	8 ... 14 µm
LT	-18...500°C	0...1000°F	8 ... 14 µm
MT	200...1000°C	400...1800°F	3.9 µm
G5	250...1650°C	500...3000°F	5 µm
P7	10...360°C	50...650°F	7.9 µm
HT	500...2000°C	950...3600°F	2.2 µm

www.raytek.com

50588, Rev. A, 02/2013 - Raytek and the Raytek logo are registered trademarks of Raytek Corporation. Specifications subject to change without notice. Raytek is ISO 9001 certified.

Worldwide Headquarters
Santa Cruz, CA USA
Tel: +1 831 458 – 3900
+1 800 227 – 8074
solutions@raytek.com

European Headquarters
Berlin, Germany
Tel: +49 30 47 80 08 0
Fax: +49 30 4 71 02 51
raytek@raytek.de



China Headquarters
Beijing, China
Tel: +86 10 6438 4691
info@raytek.com.cn

France
info@raytek.fr
United Kingdom
ukinfo@raytek.com

Raytek[®]
A Fluke Company